

Statistical Mechanics (II): Homework 4 (due on December 14)

Problem 1 Bond percolation in two dimension

Consider a two dimensional square lattice. Each bond on this lattice is occupied with the probability p . The left part of Fig. 1 is a typical configuration of bonds that are occupied (represented by a solid line). The lattice is said to be percolated if it becomes possible to march over these bonds from one side of the lattice to another side of the lattice. Obviously, the percolation is possible for large p . There exists a threshold probability p_c so that when $p \geq p_c$, percolation is possible. Now consider a decimation process in which we renormalize the lattice by knocking out every second site, as depicted in Fig. 1. Then we join two sites on the renormalized lattice with a bond if there were two bonds on the old lattice joining those two sites. Calculate the probability p' in terms of p for a bond on the new lattice being occupied. Continue this decimation process and find the fixed point of probability p^* . Argue that $p^* = p_c$.

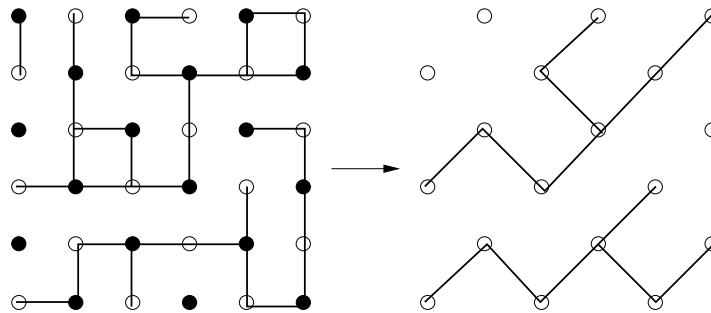

FIG. 1: A decimation process for bond-percolation problem

Problem 2

Consider a spin-1 Ising chain, i.e., with each s_i taking values $0, \pm 1$. The coupling is still $Ks_i s_{i+1}$. Use the $b = 2$ decimation process to remove every second spin. Show that this introduces new terms into the Hamiltonian. Construct explicit recursion relations and show that it suffices to include the extra terms $h_2 s_i^2$ and $K_4 s_i^2 s_{i+1}^2$ in the space of Hamiltonian. Assume $h = 0$ throughout.

Problem 3 Treat the 1d Ising model using $b = 3$, i.e., remove 2 out of every 3 spins at each step. Derive recursion relation for K and h . Show that the exponents λ_t and λ_H are the same as those for $b = 2$.

Problem 4 If we define the measure of integration over complex numbers by

$$\frac{dz^* dz}{2\pi i} \equiv \frac{d\text{Re}(z)d\text{Im}(z)}{\pi},$$

show that

$$\int \prod_{i=1}^n \frac{dx_i^* dx_i}{2\pi i} \exp(-x_i^* H_{ij} x_j + J_i^* x_i + J_j x_j^*) = (\det H)^{-1} \exp(J_i^* H_{ij}^{-1} J_j),$$

where H is any matrix with a positive Hermitian part.

Problem 5 Area of unit sphere in d dimension

Consider a d -dimensional Gaussian integral

$$\int_{-\infty}^{\infty} \prod_{i=1}^d dx_i \exp(-\sum_{i=1}^d x_i^2).$$

On one hand, it can be performed as the one-dimensional Gaussian integral $\int_{-\infty}^{\infty} dx \exp(-x^2)$ to d power; on the other hand, by considering it in spherical coordinates, find the area of unit sphere in d dimension.

Problem 6 Consider the Landau free energy

$$G(m, T) = a(T) + \frac{b}{2}m^2 + \frac{c}{4}m^4 + \frac{d}{6}m^6$$

and assume that $b > 0$, $c < 0$, so that a first-order transition takes place. Derive an expression for the latent heat of the transition.